

# EXTRUSION INDUSTRY

BIAX FILM

MDO FILM

CAST FILM

BLOWN FILM

EXTRUSION COATING

FOAM

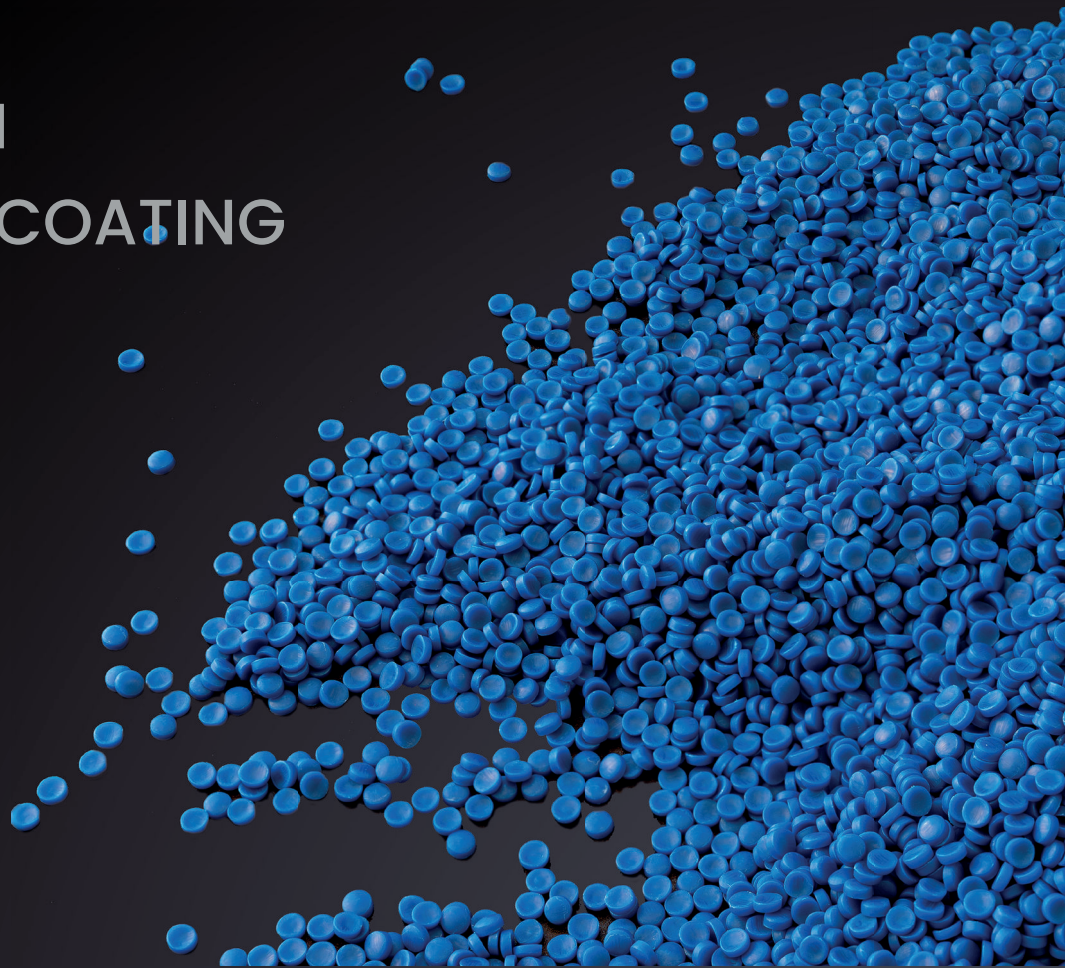

# BIAX FILM

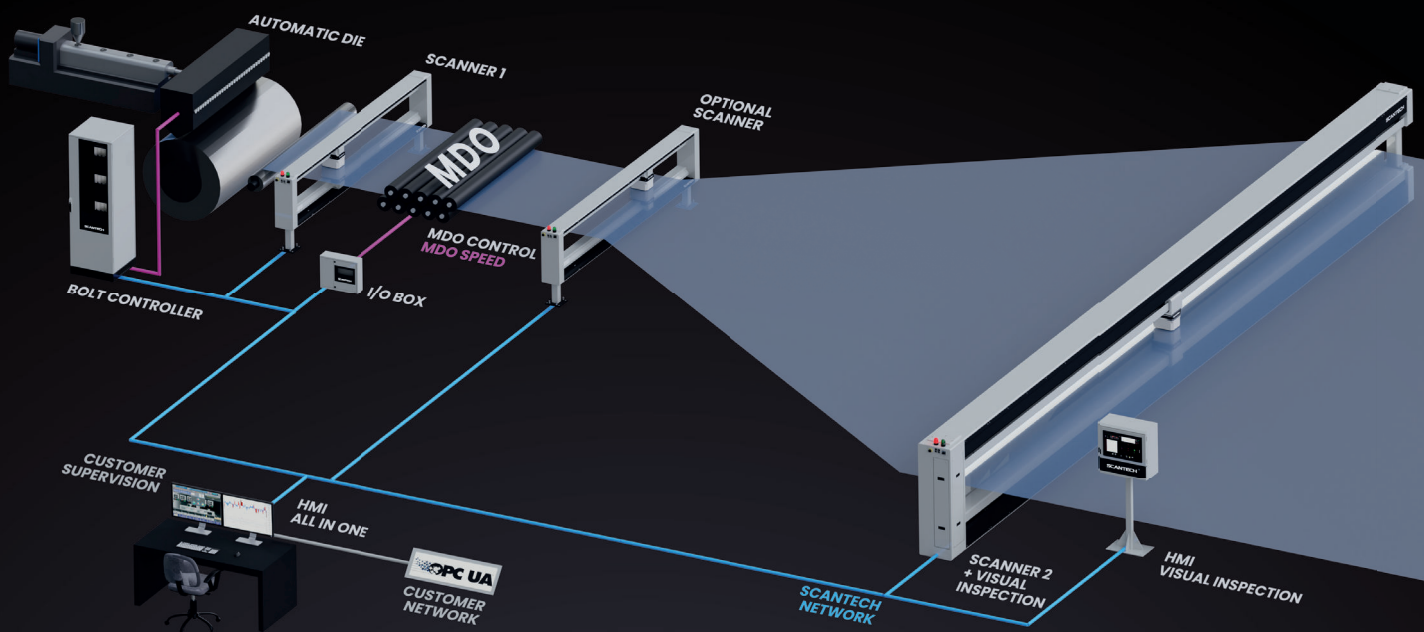

## CONTROL



**AUTO MAPPING**

APC - Auto Profile Control



**TDO STRETCH PROFILE**



**MELT FLOW MODEL**



**CASCAD CONTROL**



**BOLT CONTROLLER**

Power & Temperature control up to 360 bolts

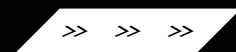

**MACHINE DIRECTION CONTROL**

# BIAX SCANNERS

Powerhouse performance

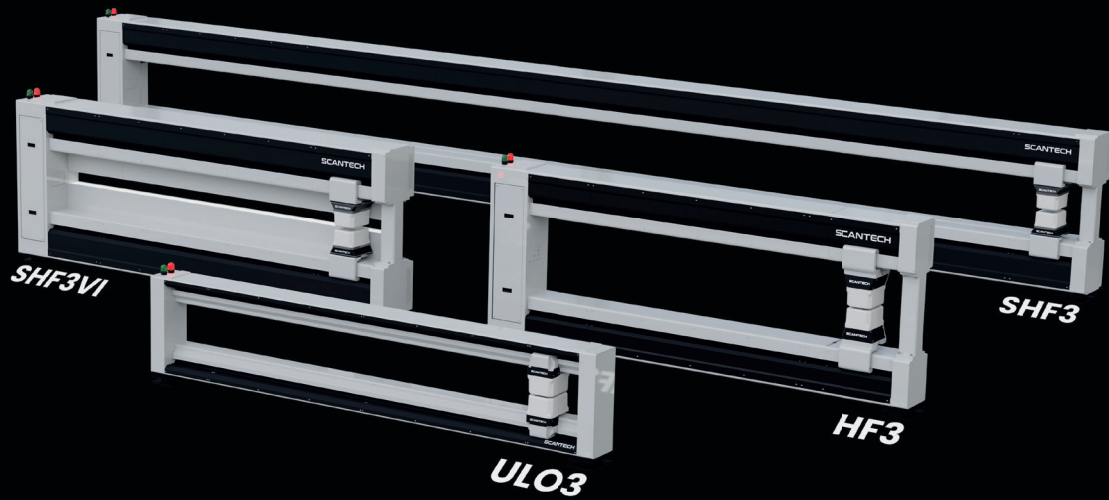

FROM 500 mm TO 15000 mm

## BIAX FILM FEATURES



True Thickness



Porosity



TDO Stretch Profile



Edge Profile



Defect Detection



Filler:  $\text{CaCo}_3$  |  $\text{TiO}_2$  |  $\text{BaSo}_4$

**FX FLEXSCAN**

**OPC UA** | **INDUSTRY 4.0**

Bolt representation and automatic die control

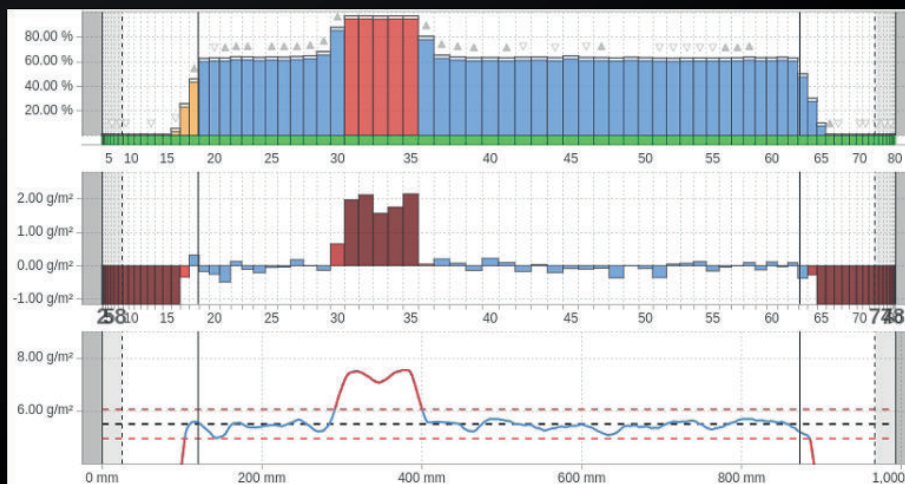

# BLOWN FILM

FASTER AND MORE ACCURATE

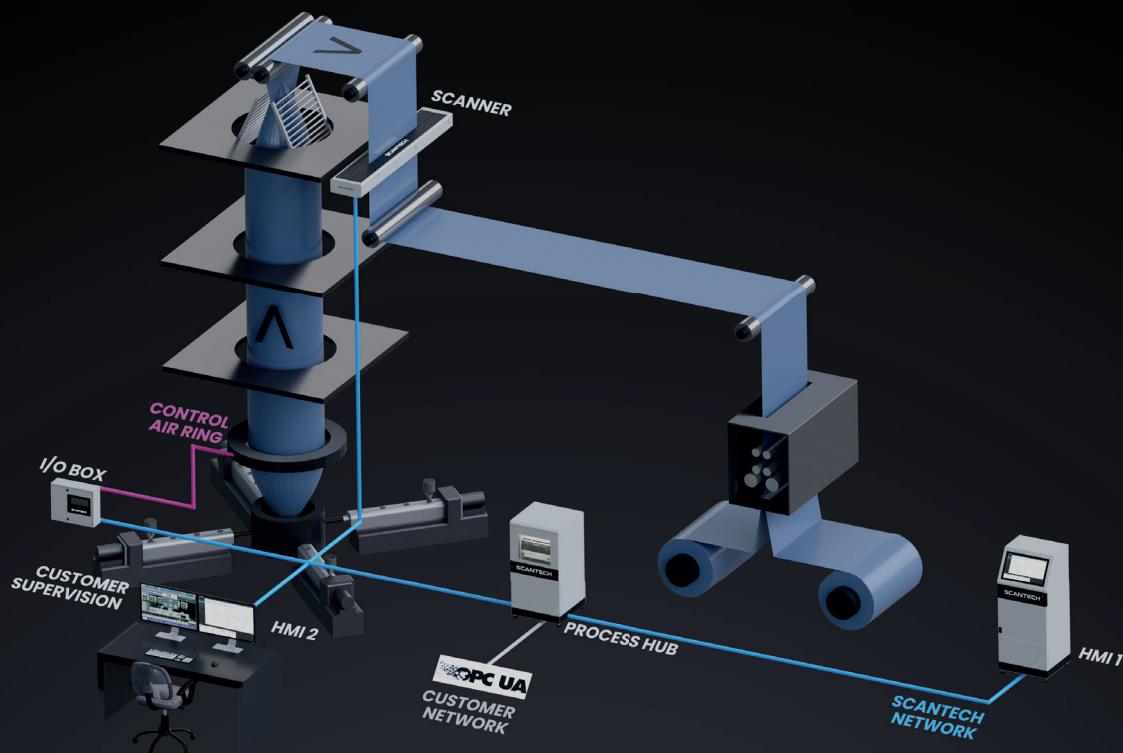

## CONTROL



ACCURATE



FAST

1 profile every 30 seconds



AUTO MAPPING

APC - Auto Profile Control

## INDIVIDUAL WINDER REPORTS



INDIVIDUAL REPORTS



INDIVIDUAL POLAR  
COLOR MAPS

# LH3 | HH3

Extremely compact design

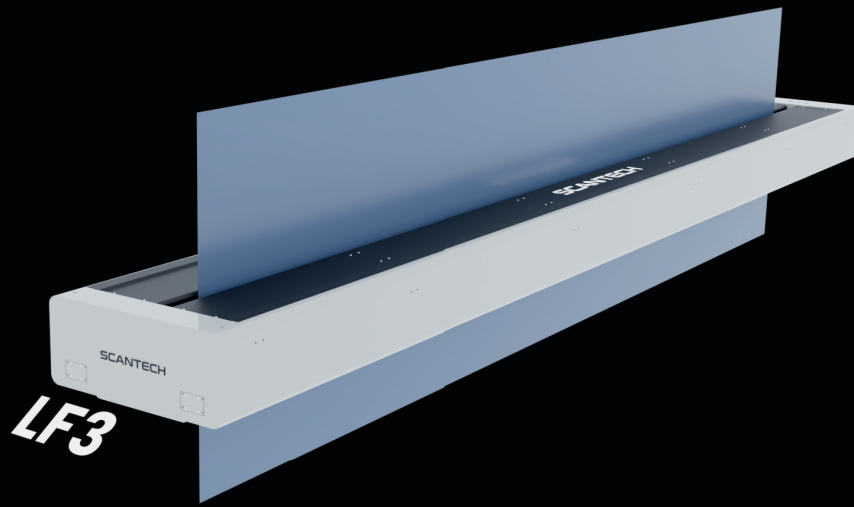

AVAILABLE WIDTHS:

LH3 FROM 500 mm TO 3500 mm | HH3 FROM 3500 mm TO 7000 mm

## BLOWN FILM MEASUREMENTS



Thickness



Barrier Layer



Filler:  $\text{CaCO}_3$  |  $\text{TiO}_2$  |  $\text{BaSO}_4$

**FX FLEXSCAN**

**CPC UA** | INDUSTRY 4.0

Interactive graphical representation of a polar profile

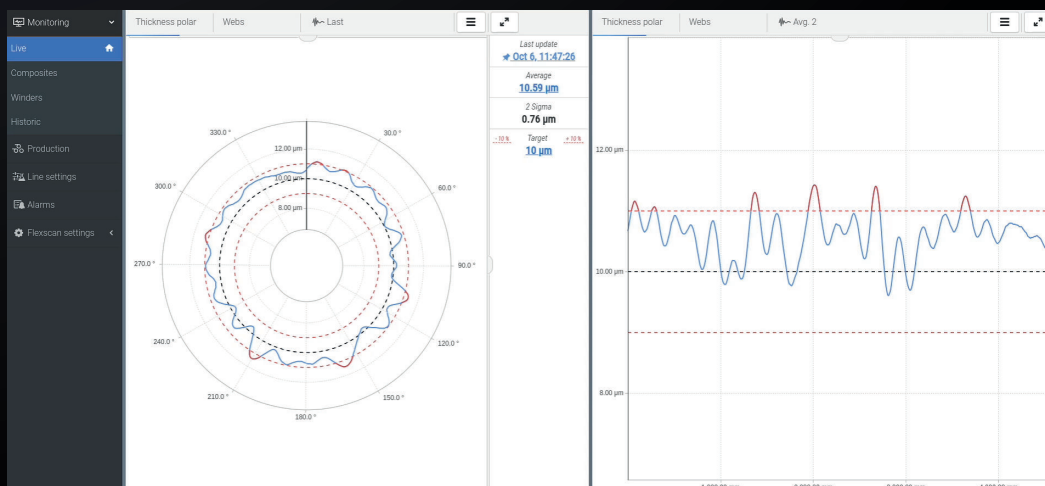



# CAST FILM

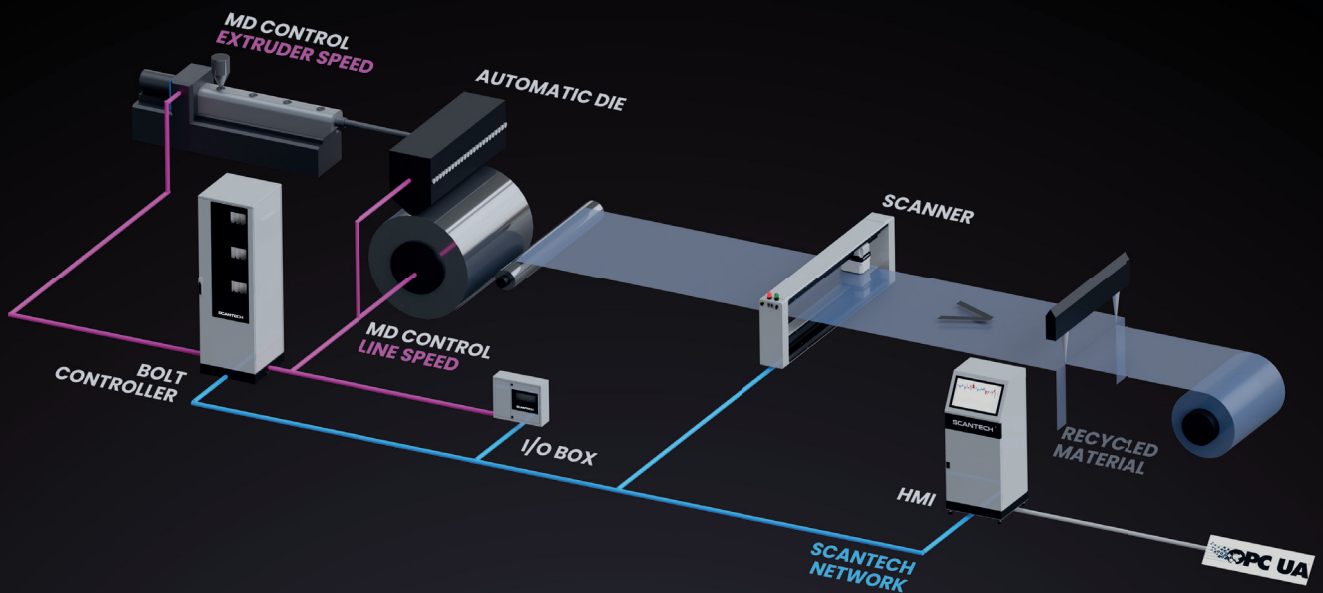

## CONTROL



### AUTO MAPPING

APC - Auto Profile Control



### MELT FLOW MODEL



### MACHINE DIRECTION CONTROL



### BOLT CONTROLLER

Power & Temperature  
control up to 360 bolts

# ULO3 | HF3 | SHF3VI

A combination of measurement solutions



AVAILABLE WIDTHS:

ULO3 UP TO 3500 mm | HF3 FROM 3500 mm TO 10000 mm | SHF3+VI FROM 10000 mm TO 13000 mm

## CAST FILMS FEATURES



Thickness



Barrier Layer



Density



Defect  
Detection



Filler:  $\text{CaCO}_3$  |  $\text{TiO}_2$  |  $\text{BaSO}_4$

**FX FLEXSCAN**

**GPC UA**

**INDUSTRY 4.0**

Bolt representation and automatic die control

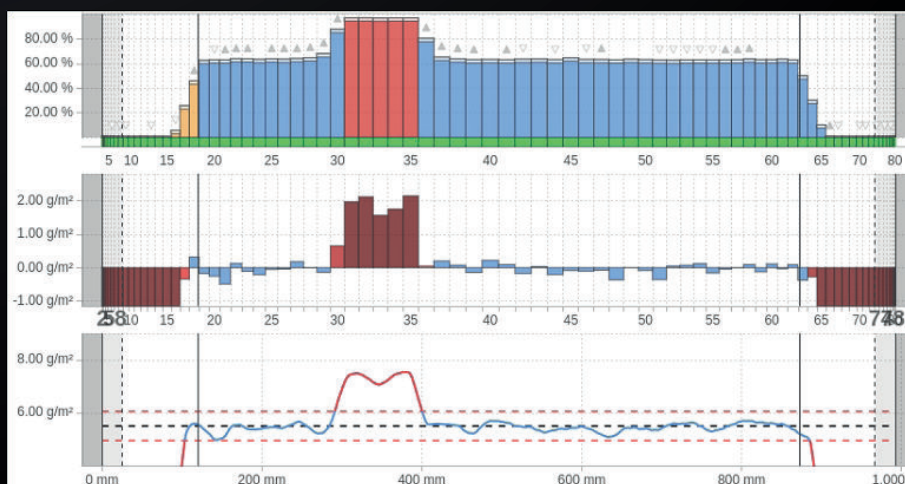

# FOAM

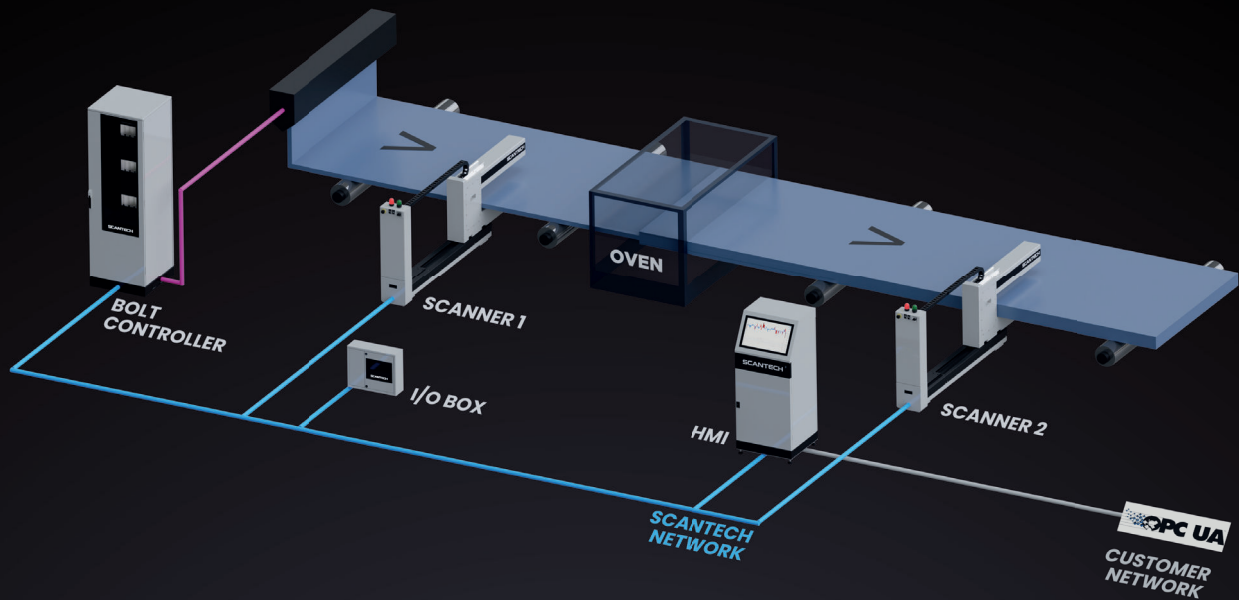

## LINE CONTROLS



### AUTO MAPPING

APC - Auto Profile Control



### EXTRUSION CONTROL



### MACHINE DIRECTION CONTROL



### BOLT CONTROLLER

Power & Temperature  
control up to 360 bolts



# CF3 | HF3



AVAILABLE WIDTHS:  
CF3 UP TO 2000 mm | HF3 FROM 3500 mm TO 10000 mm

## FOAM FEATURES



Thickness



Basis Weight



Density



Defect Detection

**FX FLEXSCAN**

CPC UA

INDUSTRY 4.0

Representation of 3 measurements: thickness, basis weight and density



# MDO FILM

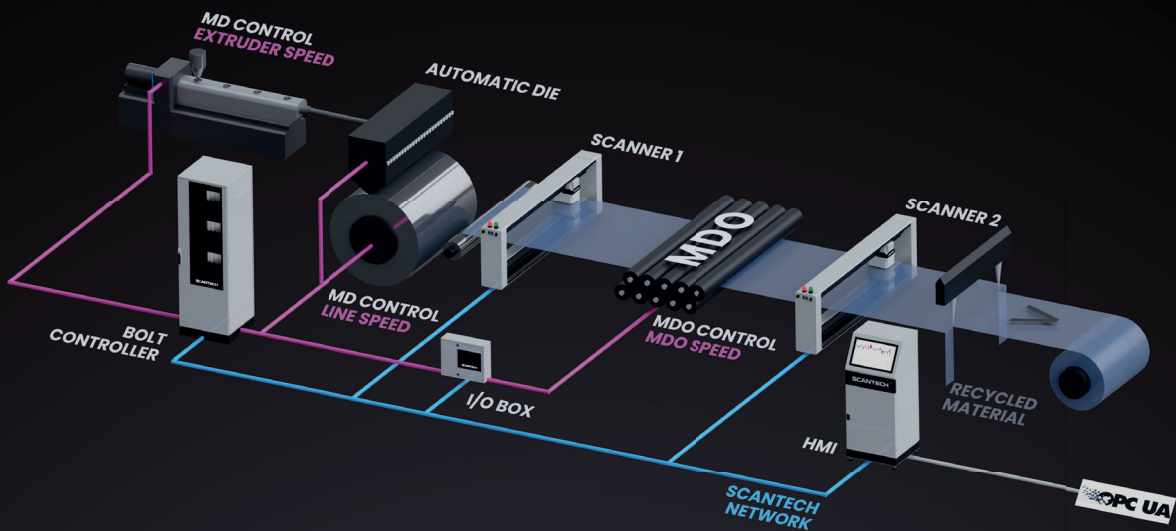

## CONTROL



### AUTO MAPPING

APC - Auto Profile Control



### MELT FLOW MODEL



### BOLT CONTROLLER

Power & Temperature control up to 360 bolts



### MACHINE DIRECTION CONTROL

# ULO3

A combination of measurement solutions



AVAILABLE WIDTHS: FROM 500 mm TO 4000 mm

## MDO FILM MEASUREMENTS



Thickness



Barrier Layer



Density



Defect Detection



Porosity



Filler  
CaCO<sub>3</sub> | TiO<sub>2</sub> | BaSO<sub>4</sub>

**FX FLEXSCAN**

**OPC UA**

**INDUSTRY 4.0**

Bolt representation and automatic die control



# EXTRUSION COATING

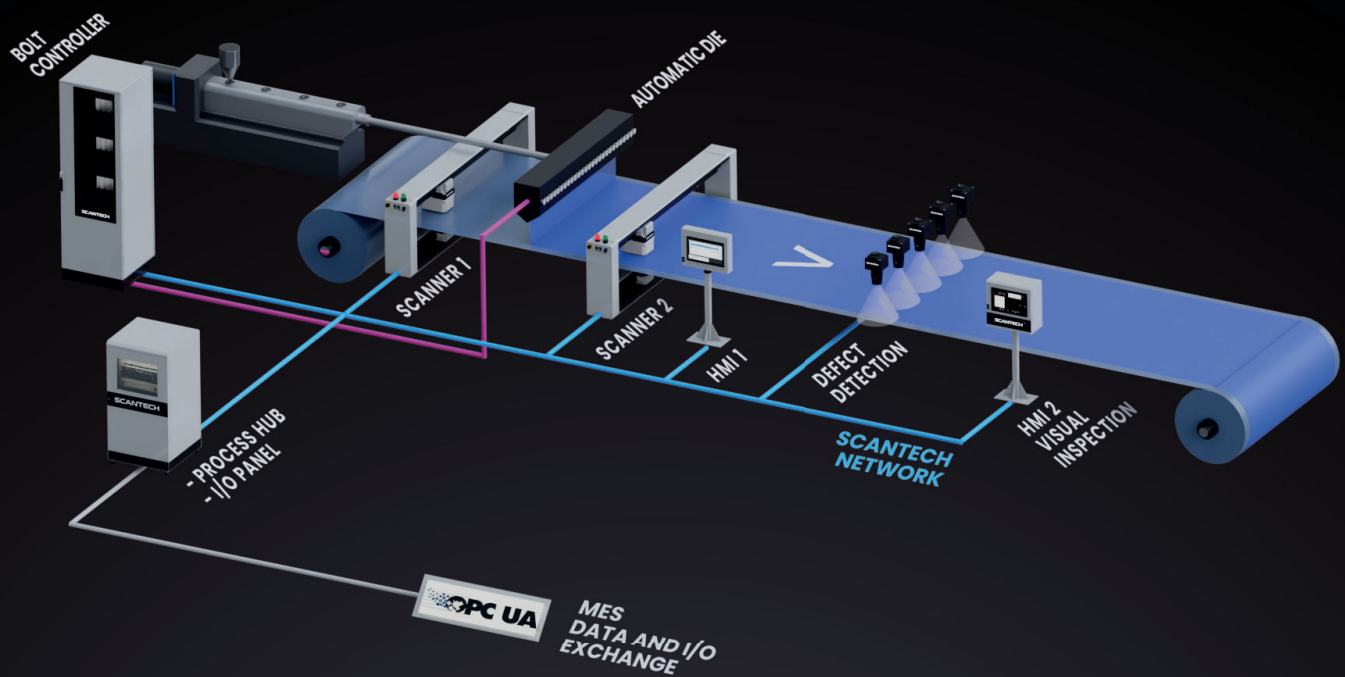

## CONTROL



### AUTO MAPPING

APC - Auto Profile Control



### SAME SPOT



### BOLT CONTROLLER

Power & Temperature control up to 360 bolts

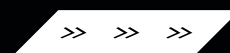

### MACHINE DIRECTION CONTROL

# ULO3

A combination of measurement solutions



AVAILABLE WIDTHS: FROM 500 mm TO 4000 mm

## EXTRUSION COATING FEATURES



Coating Thickness



Defect Detection



Differential Deduction

**FX FLEXSCAN**

**OPC UA** | **INDUSTRY 4.0**

Bolt representation and automatic die control







A WORLDWIDE GROUP



**FRANCE – HEADQUARTERS**



**CHINA & TAIWAN – SUBSIDIARIES**



**USA & BRAZIL – SUBSIDIARIES**



**ITALY – SUBSIDIARY**



**INDIA – SUBSIDIARY**



**MALAYSIA & THAILAND – SUBSIDIARIES**



**SOUTH KOREA – SUBSIDIARY**



**GERMANY – SUBSIDIARY**

SCANTECH GERMANY GMBH  
RENNWEG 60  
D - 56626 ANDERNACH  
+49 2632 / 95 89 470  
GERMANY